

# Technical Support Sheet - Operation & Maintenance Manual

## Up-Flo™ Filter

SW110&M  
Version: 1.1  
March 2021

The next generation in stormwater treatment.

Auckland Council approved. Christchurch City Council approved.

Designed to meet current stormwater regulations by targeting a wide range of pollutants including fine sediment, nutrients, bacteria, metals, oils and grease, and organics, the Up-Flo™ Filter is a high rate, modular system that combines a patented upward flow path and unique Drain Down design. The multiple treatment train capabilities of the Up-Flo™ Filter-settling, screening and filtration-make it an effective and economical stormwater treatment system.

### Benefits of Up-Flo™ Technology

- Longer filter runs
- Higher flow capacities
- Resistant to clogging
- 'Self-cleans' during drain-down period
- Media is not submerged between events
- Media does not re-release captured materials

### Capabilities

- Removes trash, sediments, nutrients, organics, metals and oils
- No pollutant washouts
- Wide range of treatment flows
- Drain down prevents leaching of captured pollutants
- Modular design allows for easy retrofit installations
- Small footprint
- Low maintenance

### Applications

- New developments and retrofits
- Catch basin or flow-through chambers
- Streets and roadways
- Car parks
- Vehicle maintenance wash-down yards
- Industrial and commercial facilities
- Wetlands protection
- Utility yards

### Operation

#### Introduction

The Up-Flo™ Filter operates on simple fluid hydraulics. It is self-activating, has no moving parts, no external power requirements and is fabricated with durable non-corrosive components. No measures are required to operate the unit and maintenance is limited to periodic inspections, sediment and floatables removal, and media pack replacement.

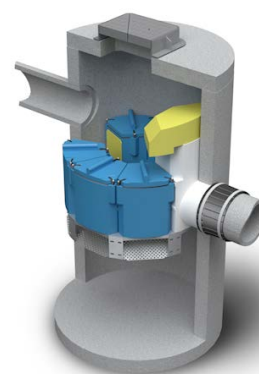

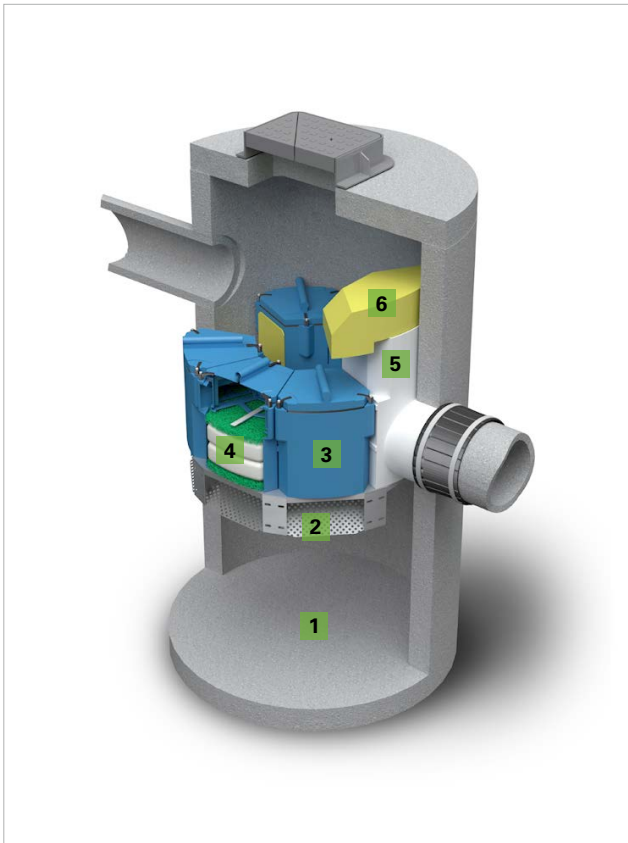

**FIG. 1** Pollutants captured in the Up-Flo™ Filter

### Up-Flo™ Filter Components

1. Sump
2. Angled screen
3. Filter module
4. Media pack
5. Outlet module
6. Bypass Siphon with Floatables Baffle

### Pollutant Capture

The Up-Flo™ Filter is designed to work as a “treatment train” by incorporating multiple treatment technologies into a single device. Trash and gross debris are removed by sedimentation and screening before they are introduced to the filtration media, preventing the filter media from clogging. The Up-Flo™ Filter is a wet-sump device. In between storm events, oil and floatables are stored on the water surface separate from the sediment storage volume in the sump (see Figure 1). The high-capacity bypass siphon also acts as a floatables baffle to prevent washout of captured floatable pollutants during high-intensity events.

### Reduced Clogging

The Up-Flo™ Filter has been designed to minimise the chance of clogging and blinding. The Up-Flo™ Filter employs a unique Drain Down design that allows the water level in the chamber to drop below the filter media between events.

The Drain Down mechanism creates a light backwashing effect that washes captured pollutants off the surface of the filter bag, helping to prevent blinding. By allowing the water to drain out, the drain-down mechanism also reduces the weight of the filter bags. This makes the bags easier and safer to remove during maintenance operations.

### Overflow Protection

The angled screens are designed to minimise the chance of ragging and blinding. The angled screens are situated below the filter modules, sheltering them from the direct path of the influent. Coarse debris settles into the sump before the runoff flows up through the screens, protecting them from blinding. In the unlikely event of a blockage, the high capacity Siphonic Bypass is designed to pass 115 l/s of excess flow directly to the outlet.

### Maintenance

#### Overview

The Up-Flo™ Filter protects the environment by removing a wide range of pollutants from stormwater runoff. Periodic removal of these captured pollutants is essential to the proper functioning of the Up-Flo™ Filter.

The Up-Flo™ Filter design allows for easy and safe inspection, monitoring and clean-out procedures.

The Up-Flo™ Filter has a wide central clearance for easy and comfortable access to the Up-Flo™ Filter components (see Figure 3).

Maintenance events can be categorised as routine or annual. Routine maintenance can include inspection, floatables removal and/or sediment removal. Routine maintenance events do not require entry into the Up-Flo™ chamber. In the case of inspection and floatables removal, a vacuum truck is not required. However, a vacuum truck is required if the maintenance event is to include sediment removal from the sump of the Up-Flo™ chamber. Annual maintenance includes media pack replacement in addition to sediment and floatables removal. In most instances, entry into the Up-Flo™ chamber is required for media pack replacement. There is the need to follow Confined Space Entry procedures when performing annual maintenance.

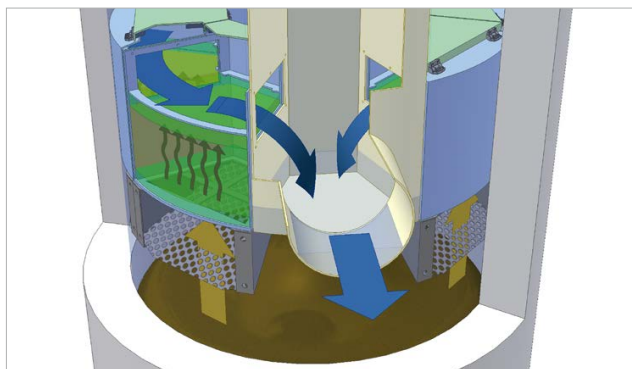

**FIG. 2** Treated Stormwater Flowpath

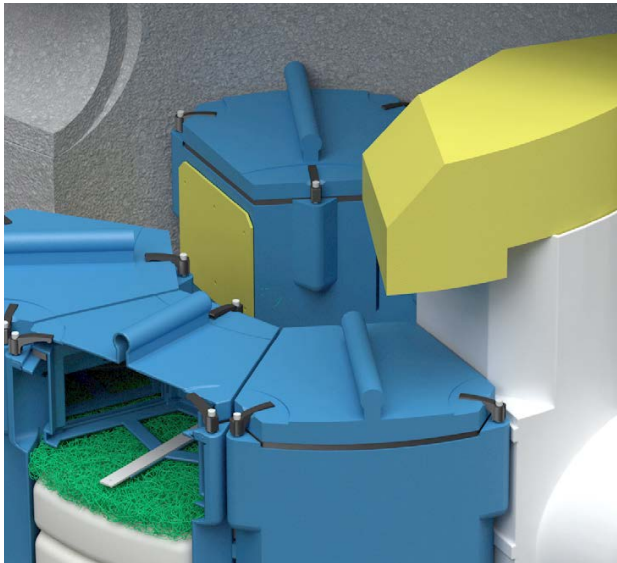

FIG. 3 The wide clearance in the Up-Flo™ Filter

### Determining Your Maintenance Schedule

The frequency of maintenance procedures can be determined in the field after installation. Hynds Stormwater, however, recommends that routine maintenance be completed at least every six months during the first year of operation. Typically, annual maintenance is recommended. During the first year of operation, the unit should be inspected every six months to determine the rate of sediment and floatables accumulation. To prevent from blocking the entry way to the filter media, the sediment must be removed before it completely fills the sump. This information can be recorded in maintenance logs to establish a routine maintenance schedule. Pollutant storage volume will be dependent on the sump depth of the Up-Flo™ Filter. A typical 1200mm round manhole Up-Flo™ Filter has 1m<sup>3</sup> of sediment storage.

Routine and Annual maintenance procedures for a typical 1200 mm diameter manhole Up-Flo™ Filter take less than 30 minutes and removes about 1100 litres of water in the process. Spent media bags weigh about 18 kg. Spent media packs should be disposed of at an appropriate landfill.

### Routine Maintenance Procedure

#### Inspection

Inspection is a simple process that does not involve entry into the Up-Flo™ chamber. Maintenance crews should be familiar with the Up-Flo™ Filter and its components prior to inspection.

#### Scheduling

- The first year following installation, it is important to inspect your Up-Flo™ Filter regularly to determine your site-specific rate of pollutant accumulation.
- Typically, inspection may be conducted during any season of the year.
- Contact Hynds for your local service provider.

#### Recommended Equipment

- Safety Equipment and Personal Protective Equipment (traffic cones, work gloves, etc.)
- Manhole lifter or crow bar to remove grate or lid
- Pole with skimmer or net
- Trash bag for removed floatables
- Up-Flo™ Filter Maintenance Log

#### Inspection Procedures

1. Set up any necessary safety equipment (*such as traffic cones*) around the access port or grate of the Up-Flo™ Filter. Safety equipment should notify passing pedestrian and road traffic that work is being done.
2. Remove the grate or lid to the manhole or vault.
3. Without entering the chamber, look down into the chamber to inspect the inside. Make note of any irregularities. (*See Figure 3 for a typical Inspection View.*)
4. Without entering the chamber, use the pole with the skimmer net to remove floatables and loose debris from the chamber.
5. On the Maintenance Log provided by Hynds Stormwater, record the date, unit location, estimated volume of floatables and gross debris removed, and the depth of sediment measured. Also note any apparent irregularities such as damaged components or blockages.
6. Securely replace the grate or lid.
7. Take down safety equipment.
8. Contact Hynds Stormwater to discuss any irregularities noted during inspection.

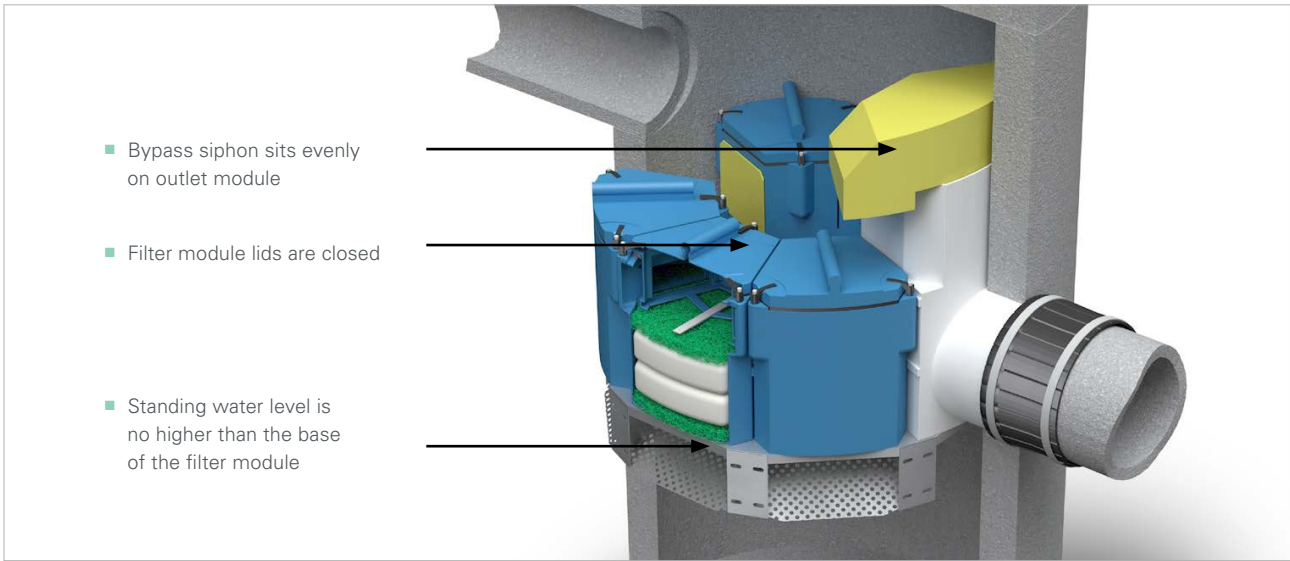

FIG. 4 Inspection view of the Up-Flo™ Filter

**Floatables and Sump Cleanout**

A commercially or municipally owned sump-vac is used to remove captured sediment and floatables (Figure 5). Floatables and loose debris can also be netted with a skimmer and pole. The access port located at the top of the manhole provides unobstructed access for a vacuum hose and skimmer pole to be lowered to the base of the sump.

**Scheduling**

- Floatables and sump cleanout may typically be done during any season of the year.
- Floatables and sump cleanout should occur as soon as possible following a spill in the contributing drainage area.

**Recommended Equipment**

- Safety Equipment (traffic cones, etc)
- Manhole lifter or crow bar to remove grate or lid
- Pole with skimmer or net (if only floatables are being removed)
- Sediment probe (such as a Sludge Judge®)
- Vacuum truck (flexible hose preferred)
- Hose, pressure washer, or other screen-cleaning device
- Up-Flo™ Filter maintenance log

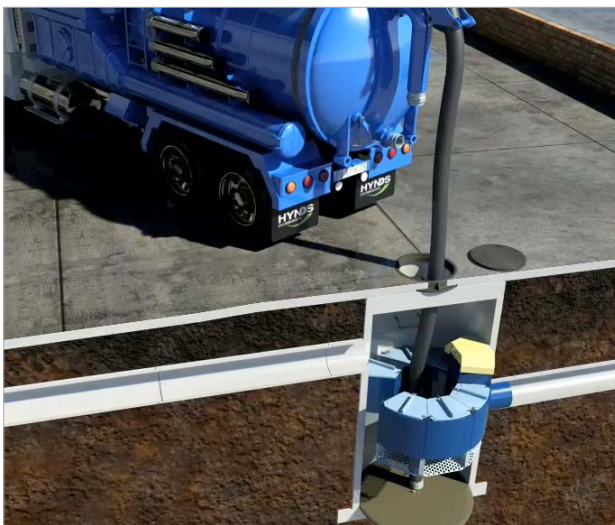

FIG. 5 Sediment is removed with a vector hose



FIG. 6 Up-Flo™ Module Exploded



### Floatables and Sump Clean Out Procedures

1. Set up any necessary safety equipment (*such as traffic cones*) around the access port or grate of the Up-Flo™ Filter. Safety equipment should notify passing pedestrian and road traffic that work is being done. TMP required.
2. Remove the grate or lid to the manhole or vault.
3. Without entering the chamber, look down into the chamber to inspect the inside. Make note of any irregularities.
4. Remove floatables stored on the surface of the water with the vacor hose or the skimmer net.
5. Using a sediment probe such as a Sludge Judge®, measure the depth of sediment that has collected in the sump of the chamber.
6. Once all floatables have been removed, drop the vacor hose to the base of the sump. Vacuum out the sediment and gross debris off the sump floor.
7. Retract the vacuum hose from the chamber.
8. Inspect the Angled Screens for blockages and ragging. If present, remove any obstructing or ragged materials from the surface using a hose or other screen-cleaning device.
9. On the maintenance log provided by service provider, record the date, unit location, estimated volume of floatables and gross debris removed, and the depth of sediment measured. Also note any apparent irregularities such as damaged components or blockages.
10. Securely replace the grate or lid.
11. Take down safety equipment.
12. Contact Hynds Stormwater to discuss any irregularities noted during cleanout.

### Media Installation

- Your Upflo filter device should have arrived with media installed inside each of the modules.
- If you haven't removed the media bags, your device is active and ready for hand over once the pipe connections and manhole or vault structure is completed.
- If you have removed the media bags the media will need to be repositioned in the module (as per fig 6).
- If you have any concerns and would like to contract a specialist maintenance operator to install the media, please contact Hynds stormwater and we can refer you to a local contact.

### Annual Maintenance Procedures

#### Replacement of media packs

Unless the Up-Flo™ Filter has been installed as a very shallow unit, it is necessary to have a trained person replace the media packs.

#### Scheduling

- Because media pack replacement requires entry into the Up-Flo™ chamber, maintenance events should be scheduled during appropriate times.
- Media pack replacement should occur immediately after a spill in the contributing drainage area.



FIG. 7 Cut away view of installed Up-Flo™ filter

## Installation / Maintenance at a Glance

Type	Activity	Frequency
Routine	Inspection	Regularly during first year of installation every 6 months after the first year of installation
	Floatables Removal	Twice per year or as needed Following a spill in the drainage area
	Sediment Removal	Twice per year or as needed Following a spill in the drainage area
Annual	Media Pack Replacement	Once per year or as needed Following a spill in the drainage area



# Up-Flo™ Filter Installation Log

Installation Date: \_\_\_\_\_

Site Name: \_\_\_\_\_

Site Location: \_\_\_\_\_

OWNER		CONTRACTOR	
Name:	<input type="text"/>	Name:	<input type="text"/>
Company Name:	<input type="text"/>	Company Name:	<input type="text"/>
Address:	<input type="text"/>	Address:	<input type="text"/>
Telephone:	<input type="text"/>	Telephone:	<input type="text"/>
Email:	<input type="text"/>	Email:	<input type="text"/>

Commission Date: \_\_\_\_\_

Contractor: \_\_\_\_\_

Configuration (*circle one*):    Manhole        Vault System

Total Number of Up-Flo™ Filter Modules: \_\_\_\_\_

Call **0800 93 7473** to be directed to your local service provider.